

MODEL "251CDA"

Chain Driven Pallet Accumulating Conveyor



- **Zero pressure accumulation**
- **Mechanically operated**
- **Heavy duty construction**
- **Chain driven rollers**
- **Zone connections outside frame for easy installation**

STANDARD SPECIFICATIONS

Frame - Heavy duty 12½" deep x 7 gauge powder painted formed steel channel with heavy duty cross braces. Frames are bolted together with splice plates and floor supports.

Rollers - 2½" diameter x 11 gauge steel rollers, grease packed and labyrinth sealed bearings, 11/16" hex shaft. Rollers are spaced on 4" or 6" centers, set 7/8" low.

Floor Supports - Adjustable 25⅝" to 30¼" (HD-4) from floor to top of roller, for each end of conveyor and at each bed joint along with knee braces for each support. Supports on 5 foot centers, change with zone length. Minimum elevation with standard drive location 24".

Drive - Located near center of conveyor length, underneath conveyor frame.

Drive Chain - RC 40 chain used for roller-to-roller connections, RC 60 chain drives each zone. Chains are totally enclosed by metal guards.

Accumulation Zones - Standard zones are 60" long with maximum of 30 zones per single drive.

Motor - ¾ HP 230/460-3-60 TE motor.

Conveyor Speed - 30 FPM constant roller speed.

Capacity - Minimum unit load - 50 pounds. 4000 pounds maximum unit load. Total conveyor live load not to exceed Load Capacity Chart. For loads less than 50 lbs., consult factory.

Speed Reducer - Heavy duty, sealed worm gear, C-Face.

Bearings - Sealed prelubricated with cast iron housings.

OPTIONAL EQUIPMENT

Accumulation Zones - 4" roller centers 36", 40", 44", 48", 52", 56" and 72" long. 6" roller centers 36", 42", 48", 54" and 72" long. Frame lengths change with zone lengths.

Tread Rollers - 2⅝" diameter x 7 gauge steel, 1/16" hex shaft.

Floor Supports - Higher or lower supports available, adjustable or fixed type.

Side Mounted Drive - Drive unit mounted to side of conveyor in lieu of underneath conveyor frame. 14" minimum elevation to the top of roller.

Conveyor Speed - Constant and variable speeds between 10 and 70 FPM available.

Limit Switch - To provide signal for customers infeed equipment.

Time Delay - Allows for product to be unloaded from discharge zone of conveyor without immediate movement of next load into discharge zone.

Motor - Single phase, energy efficient, explosion proof, etc. Other HP available.

Electrical Controls - Magnetic starters and push button stations; manual motor starters with overload protection, others.

Rollers Set High - Rollers set ¼" high above side rail. Frame is 11⅜" deep x 7 gauge formed steel channel.

MODEL "251CDA"



Bed Length	Conveying Surface	34"	40"	46"	52"	59"
	Between Frame Width	37"	43"	49"	55"	61"
	Overall Frame Width	41"	47"	53"	59"	65"
		Rollers on 4" Centers				
10'	Weights (lbs.)	1378	1483	1588	1693	1799
15'		1964	2117	2270	2423	2577
20'		2549	2570	2951	3152	3354
25'		3135	3384	3633	3882	4132
30'		3720	4017	4314	4611	4909
40'		4891	5284	5677	6070	6464
50'		6062	6551	7040	7529	8019
60'		7233	7818	8403	8988	9574
70'		8404	9085	9766	10447	11129
80'		9575	10352	11129	11906	12684
90'		10746	11619	12492	13365	14239
100'	11917	12886	13855	14824	15794	

Note: Overall lengths in chart are for 60" zones. Other zone lengths will affect overall length.

Load Capacity Charts

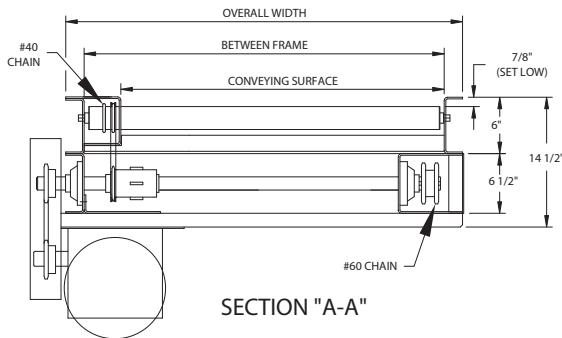

Accumulated			Moving		
Conveyor Speed @ 30 FPM			Conveyor Speed @ 30 FPM		
HP	Total Load (lbs.)		HP	Total Load (lbs.)	
	Up to 50'	Up to 100'		Up to 50'	Up to 100'
3/4	12000	7500	3/4	6000	3750
1	18000	13000	1	9000	6500
1 1/2	30000	25000	1 1/2	15000	12500
2	42000	37000	2	21000	18500

NOTE- Minimum elevation with 3/4 H.P. motor drive mounted underneath conveyor is 24".

Capacities based on 50% of load moving at same time.

