

MODELS "190CLRS" and "190CLRSS" V-Belt Spurs

NOTE:
 Model shown
 is 190CLRSS.



- **Diverging or converging applications**
- **Positive alignment of package**

STANDARD SPECIFICATIONS

Driving Belt - "B" section V-belt.

Bed - Roller bed width between rails 15", 21", 27", 33" and 39". 7¹/₂" x 1¹/₂" x 12 gauge powder painted formed steel channel frame.

Tread Rollers - 2¹/₂" diameter tapered to 1¹¹/₁₆" diameter plated and 1.9" diameter x 16 gauge plated steel tread rollers, 7⁷/₁₆" hex shaft.

Pressure Sheaves - 3" diameter x 3³/₈" bore, adjustable to give required driving force.

Take-Up - Screw take-up provided to insure proper V-belt tension. Mounted underneath conveyor.

Tangent - 12" long, on one end of curved spur.

Floor Supports - Adjustable 31¹/₂" to 45¹/₂" from floor to top of rollers.

End Drive - Mounted below bed section.

Bearings - Sealed prelubricated with cast iron housings.

Speed Reducer - C-Face mounted heavy duty worm gear reducer.

Motor - 1/2 HP 230/460-3-60 TE motor.

Belt Speed - 60 FPM constant.

Capacity - 540 lbs. total distributed live load.

OPTIONAL EQUIPMENT

Guard Rails - Adjustable channel, continuous channel, steel guard rails available.

Floor Supports - Lower or higher supports are available. Minimum elevation, 17" from floor to top of rollers.

Ceiling Hangers - 1/2" diameter threaded rods 8 feet long with locking nuts and mounting hardware. Other lengths are available.

Side Mounted Drive - End drive mounted to side of conveyor section. Specify side. Minimum elevation - 9¹/₂" from floor to top of rollers.

Motor - Single phase, energy efficient, explosion proof, etc. Other HP available.

Belt Speed - Constant and variable belt speeds available.

Electrical Controls - Magnetic starters and push button stations; manual motor starters with overload protection, others.

MODELS "190CLRS" and "190CLRSS"



CURVE SPUR "190CLRS"									
Overall Width	Width Between Frame	Radius	A		B		Weight (lbs.)		
			45°	30°	45°	30°	45°	30°	
18"	15"	32 1/2"	54 1/8"	59 1/8"	45 1/8"	65 5/8"	290	310	
24"	21"		58 3/8"	64 3/8"	55 3/8"	80 5/8"	335	355	
30"	27"		62 1/2"	69 1/2"	65 5/8"	95 5/8"	380	405	
36"	33"	48"	77 3/4"	88 1/8"	80 3/8"	118 3/8"	403	450	
42"	39"		82"	93 3/8"	90 5/8"	133 3/8"	432	490	

STRAIGHT SPUR "190CLRSS"							
Overall Width	Width Between Frame	A		B		Weight (lbs.)	
		45°	30°	45°	30°	45°	30°
18"	15"	27"	40"	25 1/2"	38 1/2"	209	251
24"	21"	36"	52"	34 1/2"	50 1/2"	238	286
30"	27"	45"	64"	43 1/2"	62 1/2"	269	323
36"	33"	53"	76"	51 1/2"	74 1/2"	303	363
42"	39"	61"	88"	59 1/2"	86 1/2"	332	398

"190CLRS" 30° CURVE SPUR

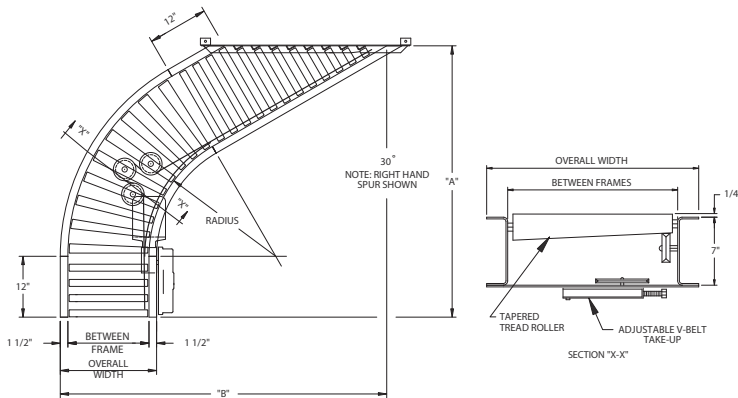

"190CLRS" 45° CURVE SPUR

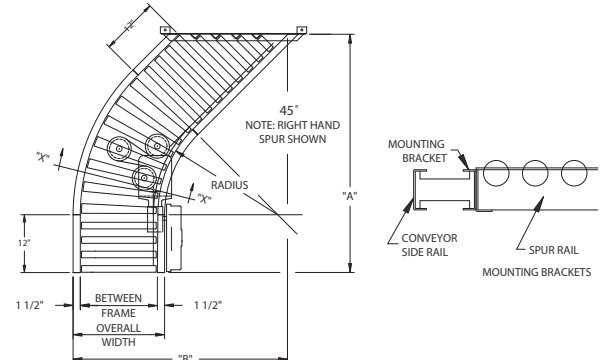

"190CLRSS" 45° STRAIGHT SPUR

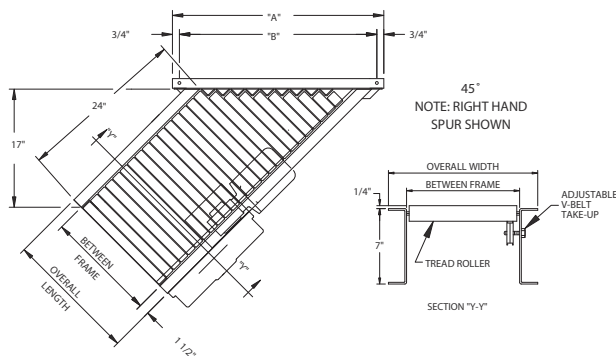

"190CLRSS" 30° STRAIGHT SPUR

